

# Model:UT-2017

**RS-232 to RS-485 port-powered Opto-isolated Converter**

## Datasheet

## 1. Overview

UT-2017 port-powered opto-isolated interface converter, compatible with RS-232C and RS-485 standards, can convert single-ended RS-232 signals to balanced differential RS-485 signals, with built-in opto-isolator, capable of providing up to 2500Vrms isolation voltage, with fast transient voltage suppression protector, this protector is designed to protect the RS-485 interface. 485 interface, using today's advanced TVS (TRANSIENT VOLTAGE SUPPRESSOR) transient voltage suppressor, under normal conditions TVS tube is a high resistance state, when the TVS tube is subjected to an instantaneous high-energy shock at both ends, it can reduce the impedance at both ends at a very high rate, absorbing a large current, thus clamping the voltage at both ends at a predetermined value, protecting the circuit components behind from damage due to transient high-voltage shock. This protector can effectively suppress lightning (LIGHTNING) and ESD, providing 600W per line of lightning surge protection power, as well as various causes of surge voltage and transient over-voltage on the line, and very small inter-pole capacitance to ensure high-speed transmission of the RS-485 interface. The RS-232 interface side is connected to the RS-232C compatible standard interface via a DB9 female connector, and the RS-485 side is the output side via a DB9 male connector. The converter is internally equipped with zero delay automatic transceiver conversion, unique I/O circuitry to automatically control the direction of data flow without any handshaking signals (e.g. RTS, DTR, etc.), half-duplex (RS-485) mode conversion, and plug-and-play. Ensures suitability for all existing communication software and interface hardware without any software modification to the previous RS-232 based operation.

UT-2017 passive opto-isolated interface converter can provide reliable connection for point-to-point and point-to-multipoint communication. Point-to-multipoint allows 32 RS-485 interface devices to be connected per converter, with data communication rate 300-38400bps, and supported communication methods are RS-232 to RS-485 conversion.

## 2. Major Functions & Features

- Support RS-232 to RS-485 port-powered opto-isolated converter

## 3. Technical Parameters

- Interface characteristics: The interface is compatible with EIA/TIA RS-232C and RS-485 standards
- Electrical interface: RS-232 interface input is DB9 female connector, RS-485 interface output is DB9 male connector
- Protection level: RS-232 interface  $\pm 15\text{KV}$  ESD protection, RS-485 interface 600W per line lightning surge protection
- Isolation degree: Isolation voltage 2500Vrms 500DC continuous
- Operating mode: Asynchronous half-duplex
- Transmission medium: twisted pair or shielded wire
- Transmission rate: 38400bps to 300m,  
9600bps to 1.2Km
- Dimension: 63mm  $\times$  33mm  $\times$  17mm
- Operating temperature: -25~70°C
- Relative humidity: 5~95%

## 4. PIN Definition

- RS-232C PIN Assignment

DB9 Female(PIN)	RS-232C interface signal
1	GND
2	Transmit data SOUT (TXD)
3	Receive data SIN (RXD)
4	DTR
5	GND
6	DSR
7	RTS
8	CTS
9	RI

- RS-485 output signal and terminal pin assignment

Terminal block	Output signal	RS-485 half-duplex wiring
1	T/R+	RS-485(A+)
2	T/R-	RA-485(B-)
3	N/C	-
4	N/C	-
5	GND	GND
6,7,8,9	VCC	-

## 5. Product View (Appearance)



## 6. Structure Dimension

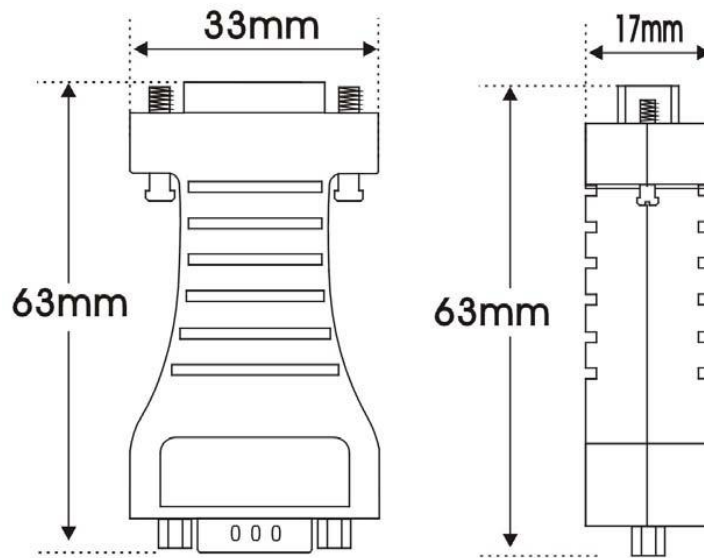

## 7. Ordering Information

### ORDERING

Model	Signal/Interface			Protection level		Baud rate	Operating Environment			Power	
	RS-232	RS-485	RS-422	RS-232	RS-485/422		Temperature		Humidity	plug and play	External power
	DB9 Female	Terminal block					-25~70°C	-40~85°C	5~95%		
UT-2017	√	√		-	±15KV ESD/600W Surge	300bps-38,400 bps	√		√	√	